

PRODUCT DATA AND INSTALLATION SHEET

MWS4 LONG RANGE MICROWAVE PRESENCE DETECTOR

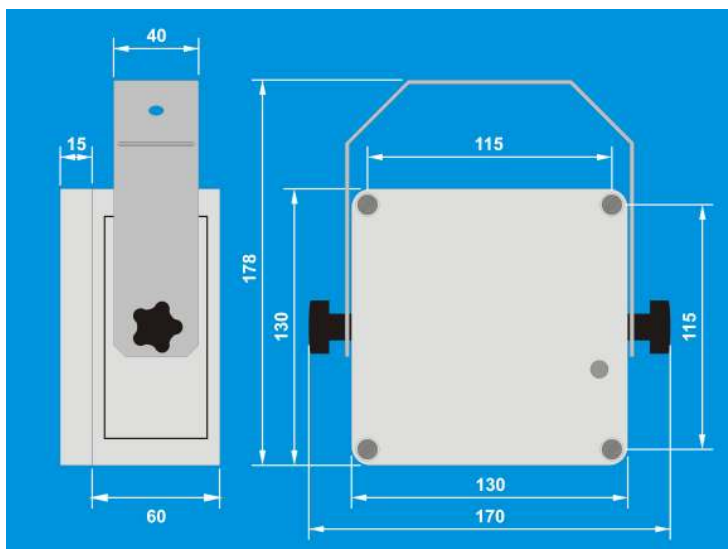

WIRING & FIXING

Wire the products as in the diagram below.

To switch from more than one position simply wire two or more units in parallel to achieve two way and intermediate switching.

The detector should be sited so that the occupants of the room fall inside the detection pattern shown overleaf.

Corridors or aisles: the unit should be placed at the end of the corridor or aisle and the sensor head should be angled to look down the corridor or aisle.

Open plan areas and offices: the unit should be mounted in a corner looking outwards and the sensor head should be angled.

Note that the higher the sensor is installed the shorter the detection range will be.

- Do not site within 2m of any lighting or ventilation equipment.
- Do not fix to a vibrating surface.
- Site as far away as possible from the surface of metal objects.
- Use a suitable cable gland for cable entries to preserve the IP rating of the unit
- The bracket must be fixed tightly to a flat surface

DESCRIPTION AND OPERATION

The MWS4 long range microwave presence detector is designed to provide automatic control of lighting, heating or ventilation loads over large areas—typically up to 60m—making it ideal for warehouses, sports halls and corridors. The MWS4 detects movement using a highly sensitive microwave detector. This works by emitting low power microwave signals and measuring the reflections as the signals bounce off moving objects. The MWS4 has a bracket that allows the area of detection to be optimised for the application.

This unit does not require a separate control unit, the sensor head and controller are combined in the same, rugged enclosure.

When movement is detected the load is turned on. When an area is no longer occupied the load will switch off after an adjustable time out period.

An internal light sensor provides additional energy saving in lighting applications. When an area is occupied lighting is only switched on when the level of natural light is below a preset level.

An integral IR sensor in the unit allows the lux settings to be changed and the sensor to be overridden using a remote control handset (part no: UHS).

Two models are available:

MWS4 - allows an external LUX sensor to inhibit the output. When the lux input terminals are closed, the output will no longer turn on.

MWS4-ABS - has an absence detection input. The unit will turn on only when the absence input is closed. The output will be kept on with occupancy and turn off automatically. If the input is pressed again during occupancy, the output will reset. Only momentary switches can be used.

INSTALLATION

Warning. This device works at mains potential. Be sure to take care when working with electricity.

1. Make sure the load is connected and in working order.
2. Isolate the mains supply to the circuit at the main consumer unit.
3. Connect the controller via the terminal block. Live supply to the L terminal, Neutral to the N terminal.
4. The output contact is an isolated contact. If required loop the Live feed to one of the terminals and take the output from the other terminal.
5. MWS4 only—connect an external lux sensor to the **LUX INPUT** terminal if using. This must be an isolated contact. When the contact is made, the output will be inhibited.
6. MWS4-ABS only—connect a momentary switch to the **ABSENCE INPUT** terminal. This must be an isolated switch.
7. Set the LUX level adjuster fully clockwise, the time to minimum (fully anticlockwise) and the sensitivity to maximum (fully clockwise) using the diagram below.
8. Apply power—the load should come on immediately.
9. Vacate the room or remain very still and wait for the load to switch off (should take no more than 2 minutes).
Check that the load switches on when movement is detected.
10. To set the LUX level wait until the level of natural daylight is just enough that lighting is required. Starting with the LUX adjuster fully anti-clockwise. Very slowly turn the adjuster clockwise until the lights come on. Note that when the LUX adjuster is fully clockwise then the lights will **always** come on with occupancy.
IR handset: LUX setting can be done using the lux up and lux down buttons—press SET first.
11. Select the time out range using the adjuster, fully clockwise is the maximum.
12. The area of detection can be varied by altering the angle of the sensor head and the sensitivity adjuster. Note: on maximum sensitivity this unit is extremely sensitive to movement and may detect through thin walls or partitions. If this causes a problem reduce the sensitivity by turning the adjuster anticlockwise.
13. *IR handset: the override on button turns the unit on permanently; the override off button turns the unit off permanently; the cancel button cancels the overrides. When an override is selected an LED will flash inside the unit.*

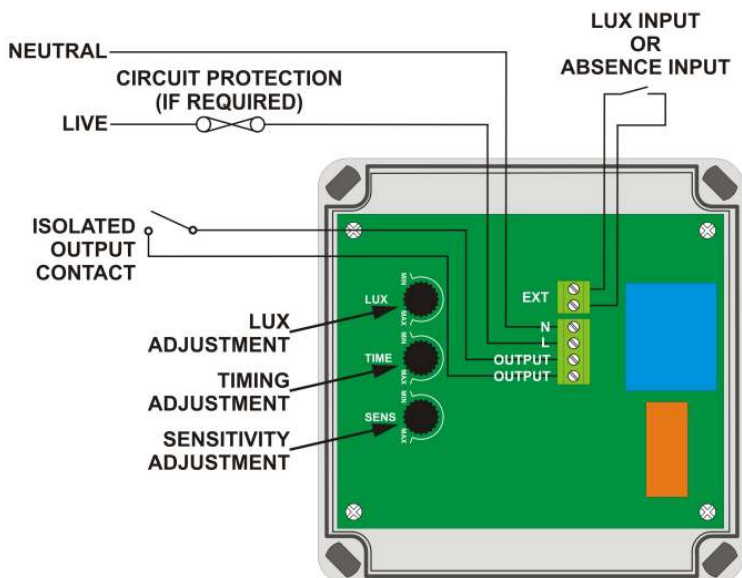

DETECTION PATTERNS

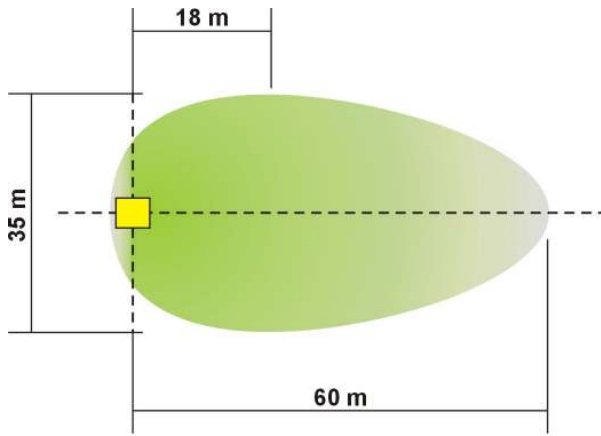

PLAN VIEW

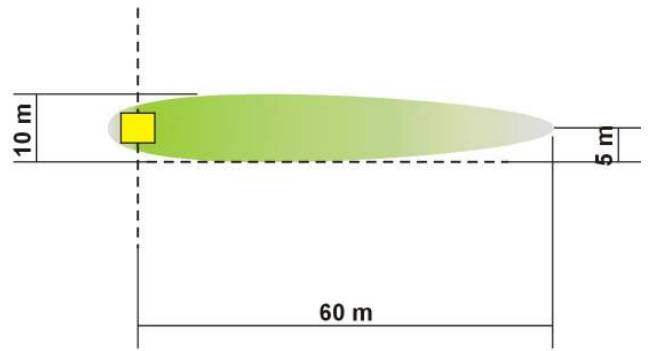

SIDE ELEVATION

AREA OF HIGH SENSITIVITY



AREA OF LOW SENSITIVITY

FAULT FINDING

LOAD DOES NOT COME ON

Check to see if the live supply to the circuit is good.

If the supply and wiring are good, check the LUX level setting. Increase the LUX level setting to allow the controller to turn on at higher ambient natural light level.

LIGHTS DO NOT GO OFF

Ensure that the area is left unoccupied for a greater time period than the time out period set using the switch.

Make sure that the sensor is not adjacent to vibrating surfaces or objects (e.g. ventilation equipment).

The unit may pick up movement through thin partitions or walls. Reduce the sensitivity by turning the adjuster anticlockwise.

The unit may pick up movement that occurs behind the sensor. Reduce the sensitivity by turning the adjuster anticlockwise.

SPECIFICATION

LOAD

10A of lighting and or ventilation including incandescent, fluorescent, compact fluorescent, low voltage (switch primary of transformer).

SUPPLY VOLTAGE	220-240 Volts AC 50 Hz
TIME OUT PERIOD	Adjustable 15 seconds to 30 minutes.
LIGHT LEVEL	Light to dark.
FIXING METHOD	Surface fixing using bracket provided
TERMINAL CAPACITY	1.5 mm ²
MATERIAL	Polystyrene
IP RATING	IP54
TYPE	Class 2
TEMPERATURE	-10°C to 35°C
SAFETY	The microwave radiation emitted by these units is extremely low power.

At a distance of > 50mm the power density is <15% of the ANSI IEEE C95.1 –1991 recommended microwave power density.
At a distance of 20mm from the unit it is <75% of recommended power density.

CONFORMITY

EMC-89/336/EEC
LVD-73/23/EEC



PART NUMBERS

MWS4	Long range microwave presence detector
MWS4-ABS	Long range microwave presence detector with absence detection input

IMPORTANT NOTICE!

This device should be installed by a qualified electrician in accordance with the latest edition of the IEE wiring regulations.