

PRODUCT DATA AND INSTALLATION SHEET

MWS5 MICROWAVE PRESENCE DETECTOR

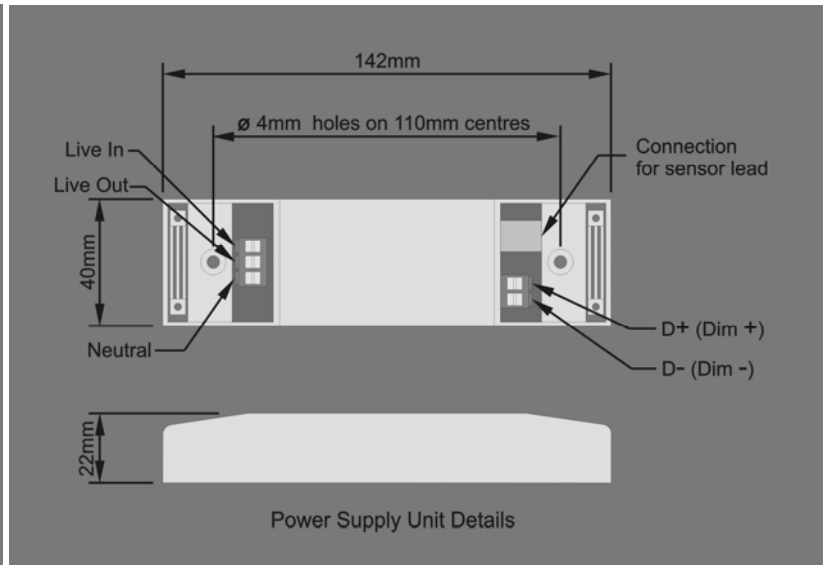
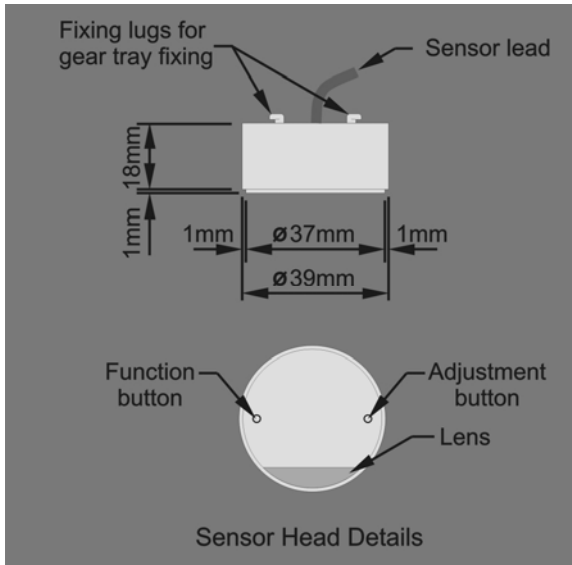

DESCRIPTION AND OPERATION

The MWS5 series of miniature microwave presence detector switches are designed to provide automatic control of lighting loads. The MWS5 detects movement using a highly sensitive microwave detector. This works by emitting low power microwave signals and measuring the reflections as the signals interact with moving objects. Microwave radiation penetrates plastic and glass allowing this sensor to be mounted inside a luminaire.

Mounting Options

The MWS5 has been designed for ceiling mounted or wall mounted applications, and is specifically suited for mounting inside luminaires.

The product consists of the following parts:

- Sensor head with integral 300mm sensor lead
- Power supply unit
- Flange mount bracket (supplied with sensor head)
- Surface mount base plate (supplied with sensor head)

The sensor head can be wall or ceiling mounted using the surface mount base plate. It can be fitted inside luminaires on the gear tray using the integral fixing lugs; on the rear side of a diffuser using the flange mount bracket; or through the front face of a fitting using the flange mount bracket.

The power supply unit is a low profile ballast-sized enclosure suitable for gear tray mounting.

Adjustment

Adjustments can be made to timing, lux and sensitivity using two small pushbuttons on the face of the sensor head. When adjustment is required, the functions are displayed via different coloured LED's behind the sensor head lens. An optional user handset can be used on IR versions to adjust the lux levels and provides a user override.

Modes of Operation

There are three modes of operation:

Presence Detection

When movement is detected the load is turned on. When the area is no longer occupied the load will switch off after the adjustable time out period has lapsed. An integral, adjustable light sensor will prevent the load being turned on when there is sufficient ambient light. In this mode an optional latching override switch can be connected to the D+ and D- terminals to provide an override off.

Absence Detection

The load is manually switched on using a momentary switch which is connected to the D+ and D- terminals. When the area is no longer occupied the load will switch off after the adjustable time out period has lapsed. If the switch contact is closed whilst the load is on, it will turn off immediately.

The presence and absence mode can be selected as part of the set-up procedure.

Dimming

Dimming versions of the MWS5 are available to provide maintained illuminance. An internal light sensor measures the light level and adjusts the output of the luminaires to maintain a constant, adjustable lux level. Note that this function only works with fluorescent fittings that have either 1-10V or DSI ballasts. When using the dimming sensor, care must be taken to ensure that the sensor head cannot directly see the lamps that it is controlling.

Switching

The MWS5 power supply unit contains a high power relay capable of directly switching most types of lighting load. For applications that require multiple luminaires to be switched using one sensor, the switched live output can power as many luminaires as required subject to the maximum current rating. It may be necessary to connect the MWS5 output to a terminal strip for distribution to other fittings.

MOUNTING OPTIONS

Direct attachment to gear tray using integral fixing lugs

Fix as in the diagram below.

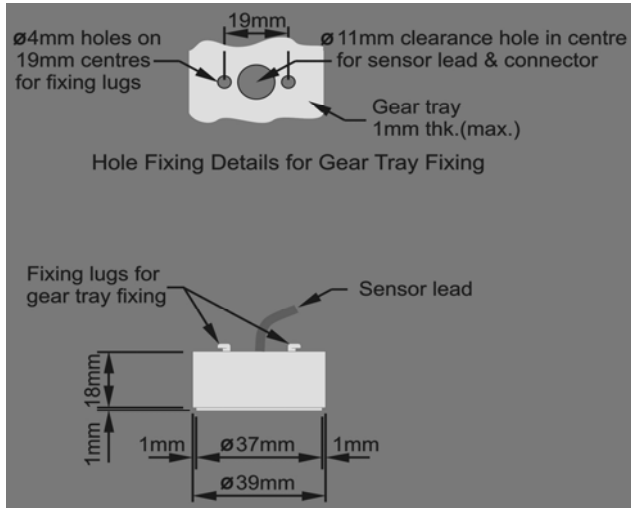

Flush fitting behind luminaire diffuser using the flange mount bracket

Glue the flange mount bracket on to the rear of the diffuser, and fasten the sensor head in place using the two longer bracket clips.

Before gluing, please ensure that the glue used is compatible with both the acrylic flange mount bracket and the diffuser material.

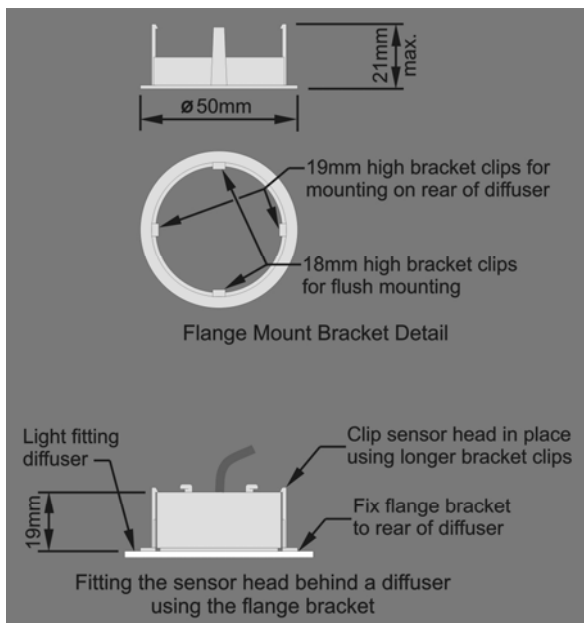

Surface mounting using the surface mount baseplate

Fix as in the diagram below.

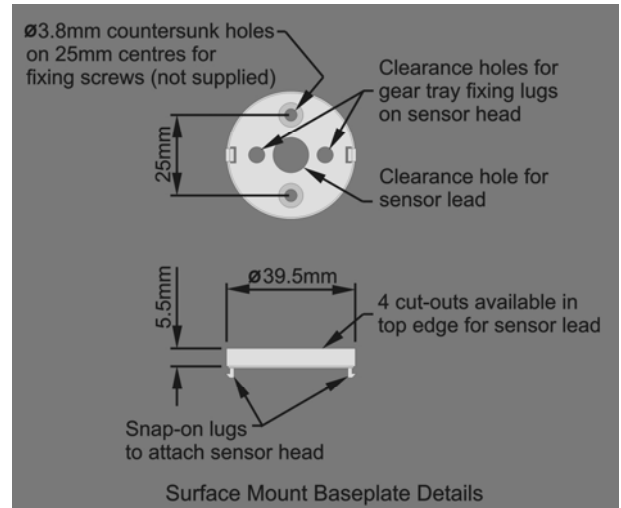

Flush fitting through gear tray or front face using the flange mount bracket

Glue the flange mount bracket on to the rear of the plate, and fasten the sensor head in place using the two shorter bracket clips.

Before gluing, please ensure that the glue used is compatible with both the acrylic flange mount bracket and the front face material.

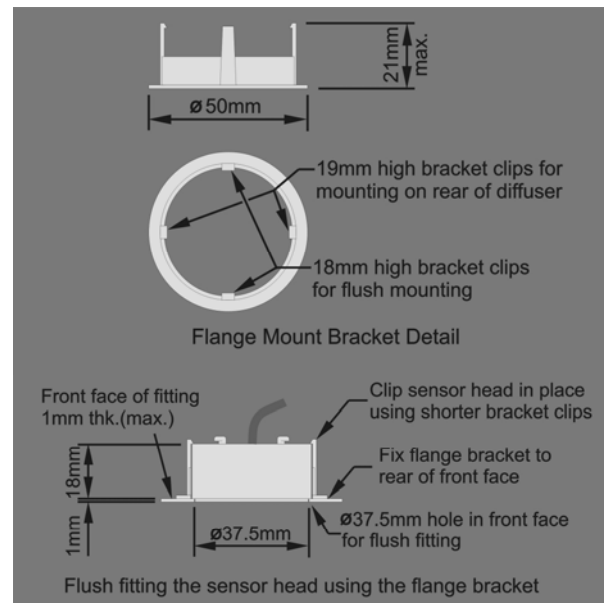

INSTALLATION AND SET-UP

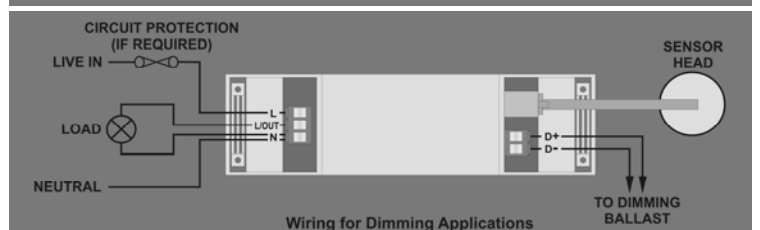
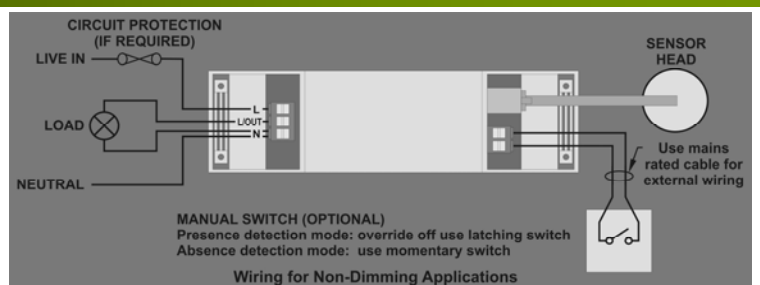
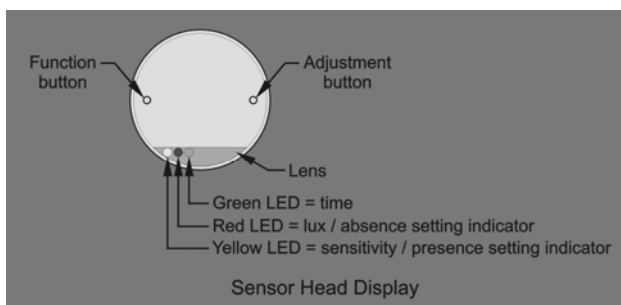

Siting the sensor

The sensor head should be sited so that the occupants of the room fall inside the detection pattern shown overleaf. Please note that the higher the sensor is installed the shorter the detection range will be.

- Do not site within 1m of any ventilation equipment.
- Do not fix to a vibrating surface.
- Keep metal objects as far away as possible from the face of the sensor head, as they will detrimentally affect the detection pattern of the product.

Connection

- Connect the power supply via the terminal block on the power supply unit. Live supply to the **L** terminal, Neutral to the **N** terminal and the load to the **LIVE OUT** terminal.
- Connect the sensor head to the power supply unit using the connector, ensuring it clicks in place.
- Non-dimming applications: a switch can be connected to the **D+** and **D-** terminals. For presence detection this is an override off switch and should be latching; for absence detection it should be momentary action. Note that any cables that are connected to manual switches must be mains rated to comply with IEE wiring regulations.
- Dimming applications: connect the **D+** (dimming up) and **D-** (dimming down) connections to the corresponding terminals on the dimming ballast.
- On power up, the load should come on immediately.
- Vacate the room or remain very still and wait for the load to switch off (on the factory preset, this should take approximately 15 minutes, but the timing out period can be adjusted down to 1 minute to speed up the set-up procedure).
- Check that the load switches on when movement is detected.

Adjustment

Time, Lux and Sensitivity

- Press and hold either button for at least 5 seconds then release: one of the LED's positioned behind the lens will flash to show which function has been selected.
- The LED will flash a number of times (between 1 and 7) to indicate the current setting (minimum = 1 flash, maximum = 7 flashes).
- To change between Time (green), Lux (red) and Sensitivity (yellow) press and release the function button until the required LED shows.
- When the function has been selected press the adjustment button to increase the setting by 1 step. Pressing the button after reaching 7 flashes will return the setting to 1 flash.
- Time settings are as follows: 1 flash = 1 minute; 2 flashes = 5 min.; 3 flashes = 10 min.; 4 flashes = 15 min.; 5 flashes = 20 min.; 6 flashes = 25 min.; 7 flashes = 30 min.
- Lux settings: 1 flash turns on when very dark ; 7 flashes turns on regardless of ambient light.
- Sensitivity: 1 flash minimum; 7 flashes maximum.
- After finishing adjustment, the LED will show the new setting 5 times and then return to operational mode.

Default settings

- Pressing and hold both buttons together : after 3 seconds the green LED lights. Release immediately to restore the factory settings as follows:
 - Presence Detection mode
 - Time = 15 minutes
 - Lux = level 7
 - Sensitivity = level 6

Mode

- To check the mode press and hold both buttons together: after 3 seconds the green LED lights—leave the buttons pressed. After a further 3 seconds the following LEDs will light:
Green/Yellow = Presence Detection mode
Green/Red = Absence detection mode
- To accept the current mode release the buttons immediately.
- To change the mode keep the buttons pressed for another 5 seconds until the LEDs change, then release.

IR Handset

- The IR handset can be used to adjust the lux level setting—press the **LUX UP** or **LUX DOWN** buttons.
- To override the sensor permanently off press the **OFF** button—the red LED will light.
- To override the sensor permanently on press the **ON** button—the green LED will light.
- To cancel an override press the **CANCEL** button.

DETECTION PATTERN

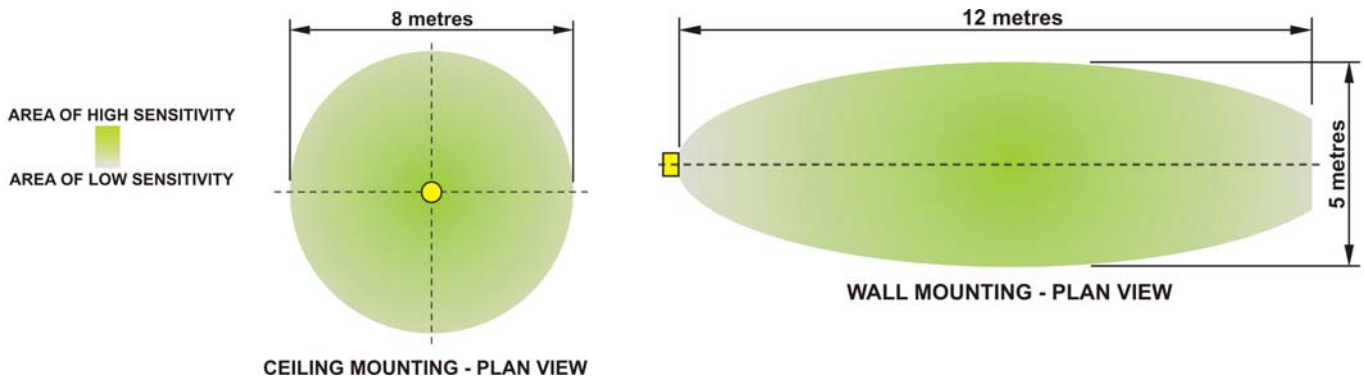

The ceiling sensor will cover a floor area of approximately 8 metres diameter at an installed sensor height of 2.4 metres. Installing the sensor head behind a diffuser will reduce the detection range by approximately 10%. Measurements taken at maximum sensitivity.

FAULT FINDING

LOAD DOES NOT COME ON

Check to see if the live supply to the circuit is good. Strap across the *L* and *LIVE OUT* terminal to ensure that the load turns on.

If the supply and wiring are good, check the LUX level setting. Increase the LUX level setting to allow the controller to turn on at higher ambient natural light level.

LIGHTS DO NOT GO OFF

Ensure that the area is left unoccupied for a greater time period than the time out period set.

Make sure that the sensor is not adjacent to vibrating surfaces or objects (e.g. ventilation equipment).

The unit may pick up movement through thin partitions or walls. Reduce the sensitivity by adjusting the sensitivity function down.

SPECIFICATION

LOAD

6 Amps fluorescent and incandescent lighting.
 3 Amps compact fluorescent lighting.
 3 Amps low energy lighting.
 3 Amps low voltage lighting (switch primary of transformer).
 Dimming output power supply versions - up to 10 dimming ballasts.
 Switch SON lighting loads via a contactor.

SUPPLY VOLTAGE

220-240 Volts AC 50 Hz.

TIME OUT PERIOD

Adjustable 1 minute to 30 minutes (stepped).

LIGHT LEVEL

Adjustable - light to dark.

FIXING METHOD

Surface fixing - see instructions
 Flush fixing - see instructions

TERMINAL CAPACITY

1.0mm²

MATERIAL

Sensor head & surface mount baseplate - Flame retardant ABS
 Power supply unit housing - Glass filled PA (Polyamide)
 Flange mount bracket & lens - PMMA (Clear Acrylic)

TYPE

TEMPERATURE

Class 2
 -10°C to 80°C

SAFETY

The microwave radiation emitted by these units is extremely low power. At a distance of > 50mm the power density is <6% of the ANSI IEEE C95.1 –1991 recommended microwave power density. At a distance of 5mm from the unit it is <84% of recommended power density.

CONFORMITY

EMC-89/336/EEC
 LVD-73/23/EEC



PART NUMBERS

MWS5	Microwave sensor head
MWS5-IR	Microwave sensor head c/w IR override
MWS5-D	Microwave sensor head for 1-10V dimming output c/w IR override
MWS5-DSI	Microwave sensor head for digital DSI dimming output c/w IR override
MWS5-PSU	Power supply unit
MWS5-PSU-D	Power supply unit with 1-10V dimming output
MWS5-PSU-DSI	Power supply unit with digital DSI dimming output
UHS	User handset override on/off, lux up, lux down
UHS-3	User handset override on/off

Due to our policy of continual product improvement CP Electronics reserves the right to alter the specification of this product without prior notice.

C.P. Electronics Ltd
 Unit 2 Abbey Manufacturing Estate
 Mount Pleasant, Wembley
 Middlesex. HA0 1RR

Tel: + 44 (0) 20 8900 0671
 Fax: + 44 (0) 20 8900 0674
www.cpelectronics.co.uk
enquiry@cpelectronics.co.uk

